

1 DESCRIPTION

Trellidor is a retractable security grille located within a securely anchored frame. The working parts of the grille (or sash) are constructed to a trellis design consisting of vertical uprights and horizontal 'flights', crossing a minimum of 3 verticals allowing the grille to expand and contract uniformly. The grille locks into a strike jamb on either or both sides and is hung from the top frame by a system of rollers. It glides on a bottom track and stacks to either or both sides.



[RETURN TO MENU](#)

FEATURES & BENEFITS

FEATURES COMMON TO ALL TRELLIDOR RETRACTABLE GRILLES	BENEFITS COMMON TO ALL TRELLIDOR RETRACTABLE GRILLES
<ul style="list-style-type: none"> • Top hung – weight of grille hangs from top track 	<ul style="list-style-type: none"> • Glides easily and is simple to operate. No rollers on the bottom track to collect dirt
<ul style="list-style-type: none"> • Manufactured from galvanised steel which is chemically treated and powder-coated prior to assembly 	<ul style="list-style-type: none"> • Corrosion resistant
<ul style="list-style-type: none"> • Award-winning Trellilok 	<ul style="list-style-type: none"> • Burglary resistant
<ul style="list-style-type: none"> • Lock integral to the frame 	<ul style="list-style-type: none"> • More resistant to burglary and neat looking
<ul style="list-style-type: none"> • Tamper proof fixings 	<ul style="list-style-type: none"> • Burglary resistant
<ul style="list-style-type: none"> • Tailor-made 	<ul style="list-style-type: none"> • Fits any architectural opening snugly
<ul style="list-style-type: none"> • 2 point locking mechanism operates from a single key position 	<ul style="list-style-type: none"> • Fewer keys, ease of operation
<ul style="list-style-type: none"> • 3 hole link flight 	<ul style="list-style-type: none"> • Door opens and closes uniformly
<ul style="list-style-type: none"> • Fully framed and anchored into the reveal 	<ul style="list-style-type: none"> • Strength
<ul style="list-style-type: none"> • Rolled steel uprights enclosing Nylon 6 components 	<ul style="list-style-type: none"> • Security and ease of operation
<ul style="list-style-type: none"> • Aluminium sill 	<ul style="list-style-type: none"> • Easy to clean
<ul style="list-style-type: none"> • Wide range of colour options 	<ul style="list-style-type: none"> • Choice
UNIQUE FEATURES OF THE STANDARD TRELLIDOR	UNIQUE BENEFITS OF THE STANDARD TRELLIDOR
<ul style="list-style-type: none"> • Range of options 	
<ul style="list-style-type: none"> > Hinge-away 	<ul style="list-style-type: none"> > Space saving
<ul style="list-style-type: none"> > Hinge-up bottom track 	<ul style="list-style-type: none"> > Removes trip hazard
<ul style="list-style-type: none"> > Cut-in tracks 	<ul style="list-style-type: none"> > Removes trip hazard
<ul style="list-style-type: none"> > Removable track 	<ul style="list-style-type: none"> > Allows unimpeded entrance
<ul style="list-style-type: none"> > Angle units 	<ul style="list-style-type: none"> > Allows tight corners to be secured
<ul style="list-style-type: none"> > Covered Track 	<ul style="list-style-type: none"> > Allows wheelchair access
<ul style="list-style-type: none"> > Side-by-side 	<ul style="list-style-type: none"> > Allows large open spaces to be secured
<ul style="list-style-type: none"> > Electric access control 	<ul style="list-style-type: none"> > Ease of operation
<ul style="list-style-type: none"> • Retracts to 15% of its original size 	<ul style="list-style-type: none"> • Access

3 SIZE

Trellidors can be applied to any width of aperture. This is achieved by means of multiple stacks on a single track which lock into each sash as in a multiple- or flexi- configuration. It is not recommended to exceed 6 metres for each single sash and 12 metres for each double sash. Also refer to side by side configurations.

1 flight
385mm - 860mm

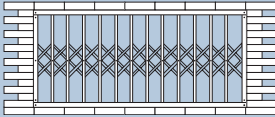

2 flights
865mm - 1550mm

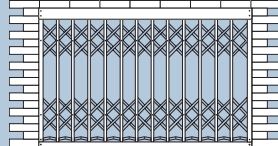

3 flights
1555mm - 2210mm

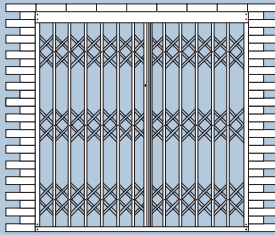

4 flights
2215mm - 2800mm

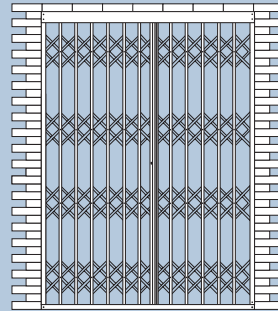

5 flights
2805mm - 3000mm

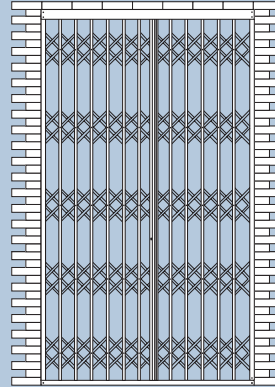

Heights in excess of 3000mm

It is usually possible to install a fixed sash above the moving sash as illustrated

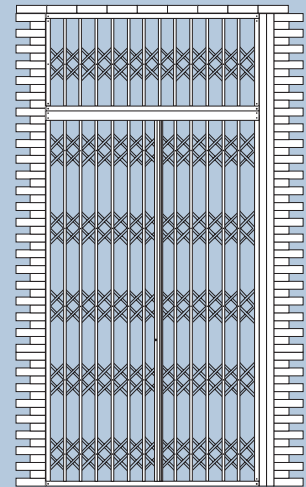

SIZE CONT.

STACK SERIES AND CLEAR OPENING

TABLE 1 SINGLE-SASH

Trellidor width		Width of stack	Width of jamb	Clear opening	
from	to			from	to
325	435	105	50	170	280
440	550	120	50	285	380
555	665	135	50	385	480
670	785	155	50	485	580
790	900	170	50	585	680
905	1015	185	50	685	780
1020	1130	200	50	785	880
1135	1245	215	50	885	980
1250	1365	235	50	985	1080
1370	1480	250	50	1085	1180
1485	1595	265	50	1185	1280
1600	1710	280	50	1285	1380
1715	1825	295	50	1385	1480
1830	1945	315	50	1485	1580
1950	2060	330	50	1585	1680
2065	2175	345	50	1685	1780
2180	2290	360	50	1785	1880
2295	2405	375	50	1885	1980
2410	2525	395	50	1985	2080
2530	2640	410	50	2085	2180
2645	2755	425	50	2185	2280
2760	2870	440	50	2285	2380
2875	2985	455	50	2385	2480
2990	3105	475	50	2485	2580
3110	3220	490	50	2585	2680
3225	3335	505	50	2685	2780
3340	3450	520	50	2785	2880
3455	3565	535	50	2885	2980
3570	3685	555	50	2985	3080
3690	3800	570	50	3085	3180
3805	3915	585	50	3185	3280
3920	4030	600	50	3285	3380
4035	4145	615	50	3385	3480
4150	4265	635	50	3485	3580
4270	4380	650	50	3585	3680
4385	4495	665	50	3685	3780
4500	4610	680	50	3785	3880
4615	4725	695	50	3885	3980
4730	4845	715	50	3985	4080
4850	4960	730	50	4085	4180
4965	5075	745	50	4185	4280

Opening width = Trellidor width - stack width - strike jamb size
 Trellidor width = opening width + stack width + strike jamb size

TABLE 2 DOUBLE SASH

Trellidor width		Width of stack	Width of jamb	Clear opening	
from	to			from	to
555	785	105	125	325	555
790	1015	120	140	560	755
1020	1245	135	155	760	955
1250	1480	155	175	960	1150
1485	1710	170	190	1155	1350
1715	1945	185	205	1355	1555
1950	2175	200	220	1560	1755
2180	2405	215	235	1750	1955
2410	2640	235	255	1960	2150
2645	2870	250	270	2155	2350
2875	3105	265	285	2355	2555
3110	3335	280	300	2560	2755
3340	3565	295	315	2760	2955
3570	3800	315	335	2960	3150
3805	4030	330	350	3155	3350
4035	4265	345	365	3355	3555
4270	4495	360	380	3560	3755
4500	4725	375	395	3760	3955
4730	4960	395	415	3960	4150
4965	5190	410	430	4155	4350
5195	5425	425	445	4355	4555
5430	5655	440	460	4560	4755
5660	5885	455	475	4760	4955
5890	6120	475	495	4960	5150
6125	6350	490	510	5155	5350
6355	6585	505	525	5355	5555
6590	6815	520	540	5560	5755
6820	7045	535	555	5760	5955
7050	7280	555	575	5960	6150
7285	7510	570	590	6155	6350
7515	7745	585	605	6355	6555
7750	7975	600	620	6560	6755
7980	8205	615	635	6760	6955
8210	8440	635	655	6960	7150
8445	8670	650	670	7155	7350
8675	8905	665	685	7355	7555
8910	9135	680	700	7560	7755
9140	9365	695	715	7760	7955
9370	9600	715	735	7960	8150
9605	9830	730	750	8155	8350
9835	10065	745	765	8355	8555

Opening width = Trellidor width - lock side stack width - strike side stack width
 Trellidor width = opening width + lock side stack width + strike side stack width

4 ASSEMBLY

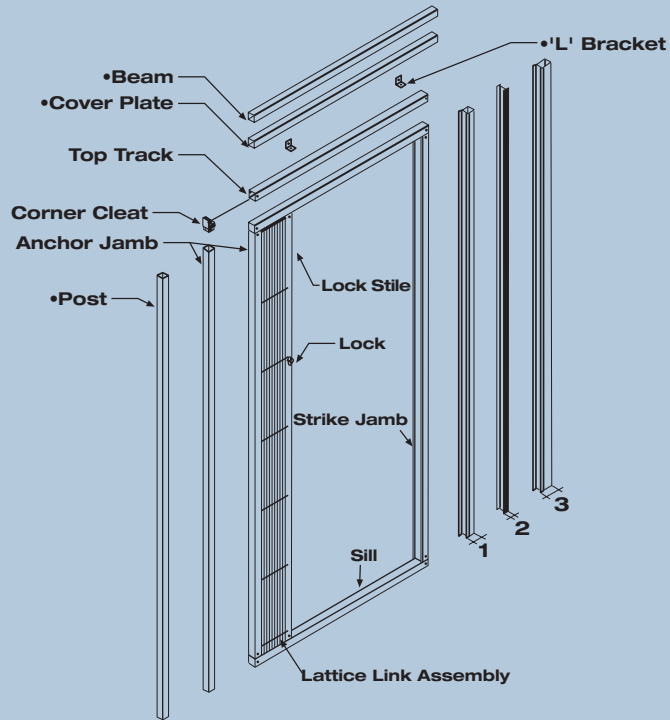

• Optional installation extras

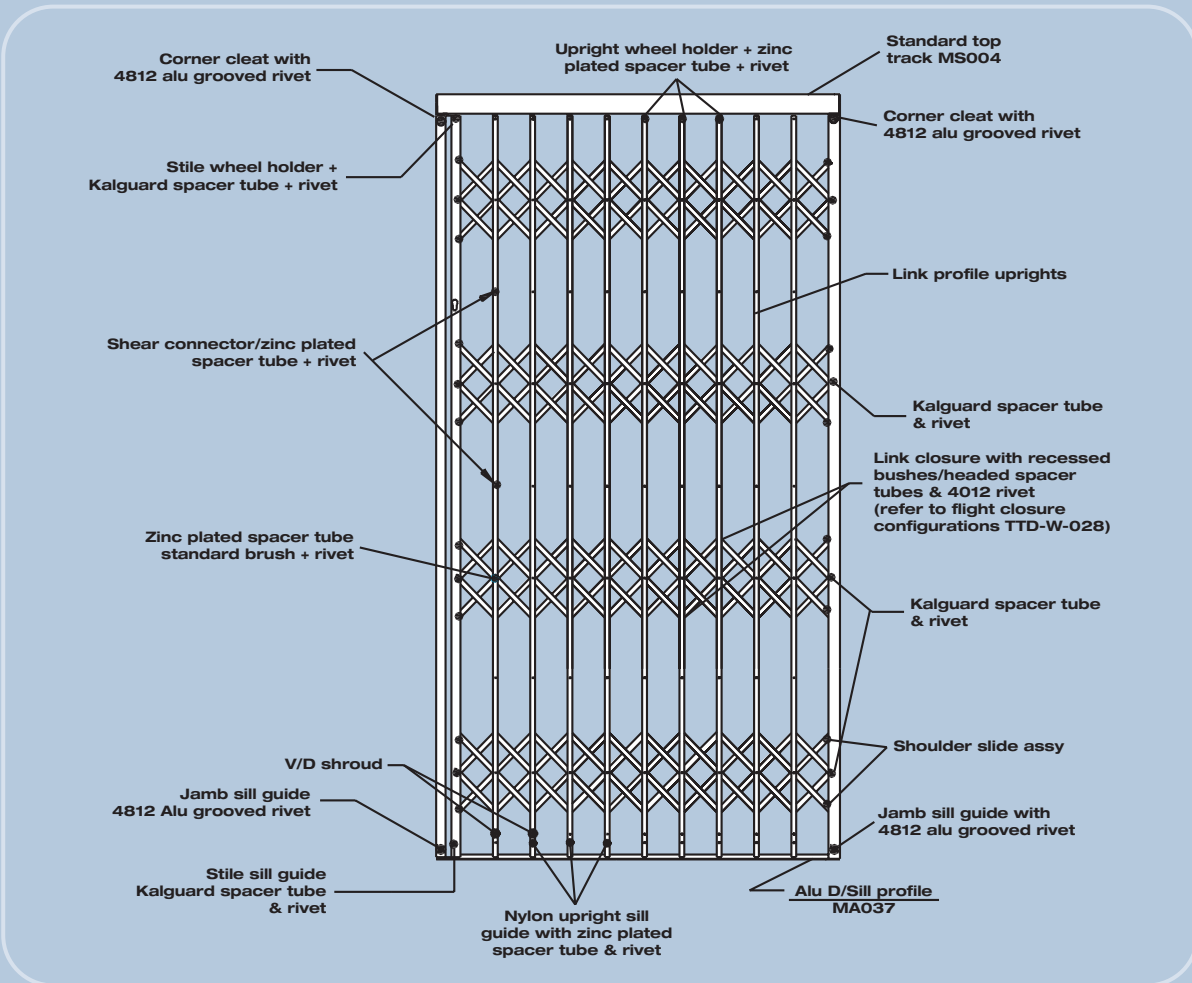

CONSTRUCTION

The exterior components and bottom track are located and fixed to form a rigid frame. The trellis sash running in this frame consists of vertical steel components joined together by means of horizontal rows of links. The linkage across the vertical upright pairs is a unique feature of the barrier construction developed by Trellcor, giving both uniformity of operation and added strength.

5.1 The **FRAME** consists of

A	Strike Jamb	Galvanised steel, powder coated
B	Top Track	Galvanised steel, powder coated
C	Anchor Jamb	Galvanised steel, powder coated
D	Bottom Sill	Aluminium

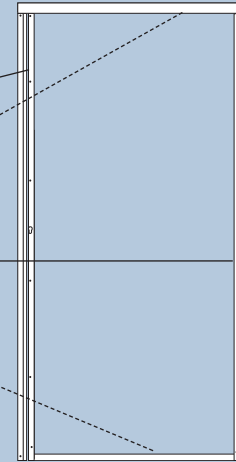

A

STRIKE JAMB

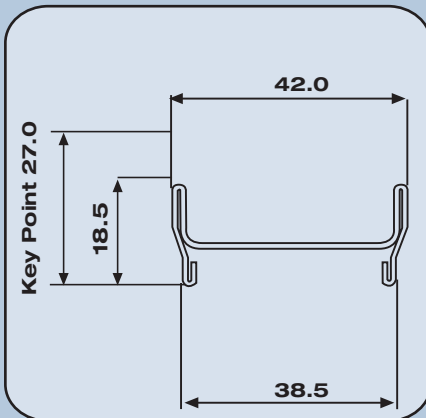

05 STRIKE JAMB

Utilised to minimise intrusion into the aperture space. Often used where unit is fitted next to aluminium patio doors with slimline frames.

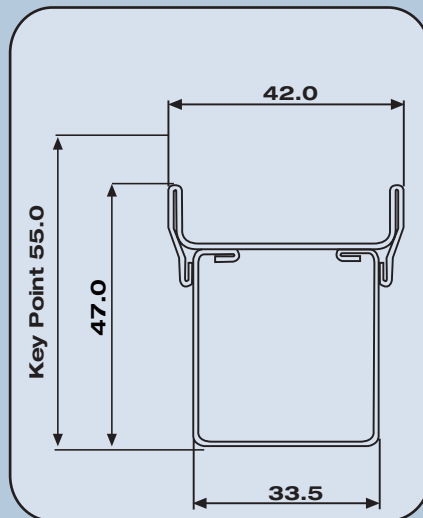

35 STRIKE JAMB

Used when key position relative to the door/window frame has reasonably free/clear access. Also reduces intrusion into aperture clear space when unit is open.

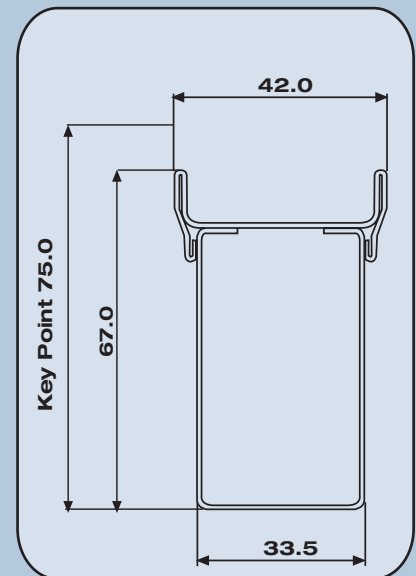

55 STRIKE JAMB

Utilised where positioning the key point away from the wall is important. Often used on doors to clear the frame.



CONSTRUCTION CONT.

B

TOP TRACK

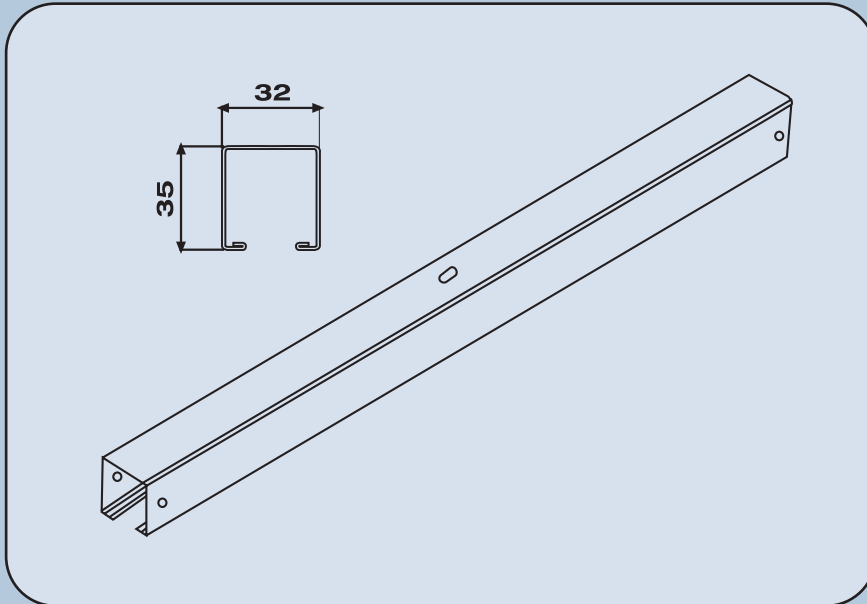

C

ANCHOR JAMB

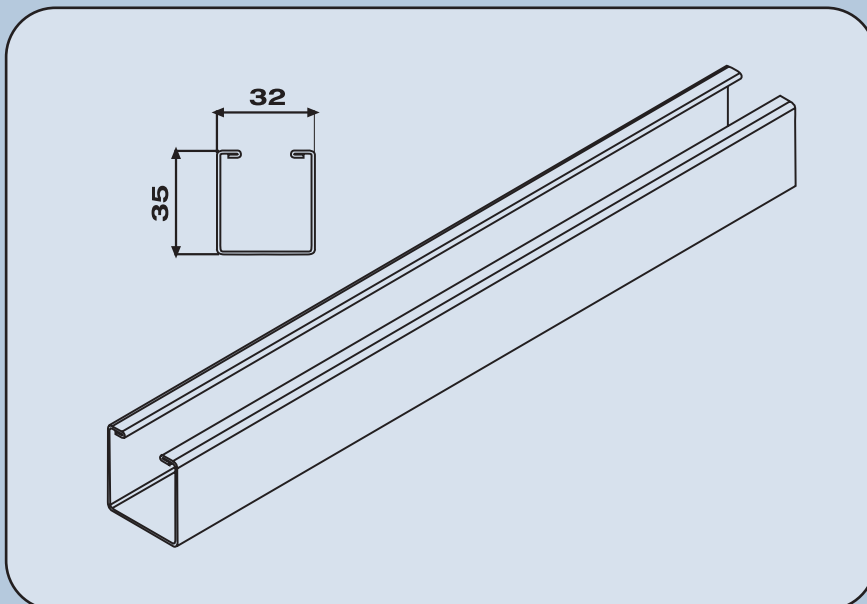

CONSTRUCTION CONT.

D

BOTTOM SILL

ALUMINIUM SILL

DIAGRAM 1

Mainly used in door applications, but can also be used in window applications where requested.
Anodised natural to 25 microns. (Can be powder coated)
Width 45mm Height 15mm (Refer 1A)
This track may also be sunk into the floor. (Refer 1B)

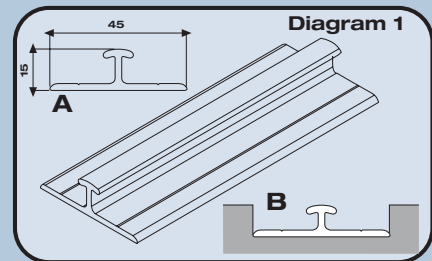

STEEL SILL

DIAGRAM 2

Mainly used in window and special door applications.
Powder coated to match the application.
Width 32mm Height 35mm. Both sill types can be hinged up or removable. Curved top and bottom tracks are available in door and window sill configurations upon enquiry.

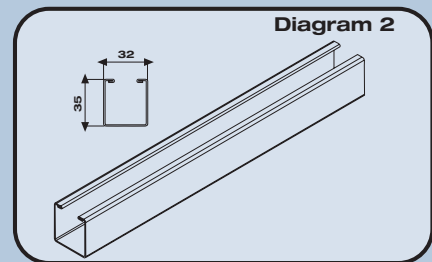

HINGED UP ALUMINIUM SILL

DIAGRAM 3 & 4

The hinge assembly for the bottom sill enables hinging of the track up into the vertical position, thus leaving the floor area clear of any obstructions. (Refer diagram 4) This enables cleaning and free movement of wheeled objects through the entrance or opening being secured. The hinging assembly as illustrated is constructed from galvanised mild steel which is powder coated to match the colour of the door. The assembly can also be ordered chromed. The latch assembly can be installed to operate from either side of the door. When in the open position with the sill hinged up, the hinged section of the sill will hold back the stack.

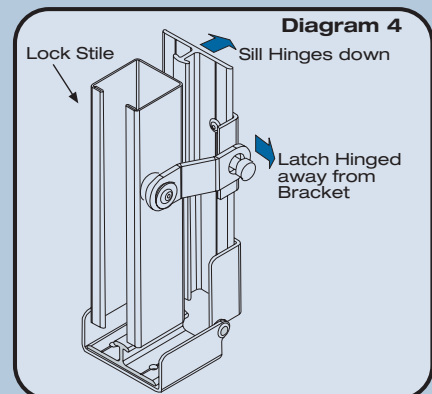
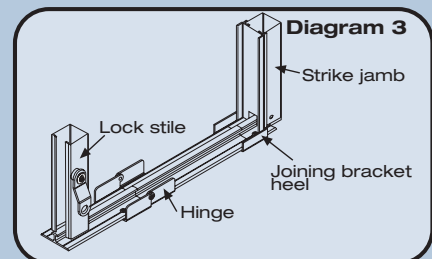

5.2 TRELLIS SASH

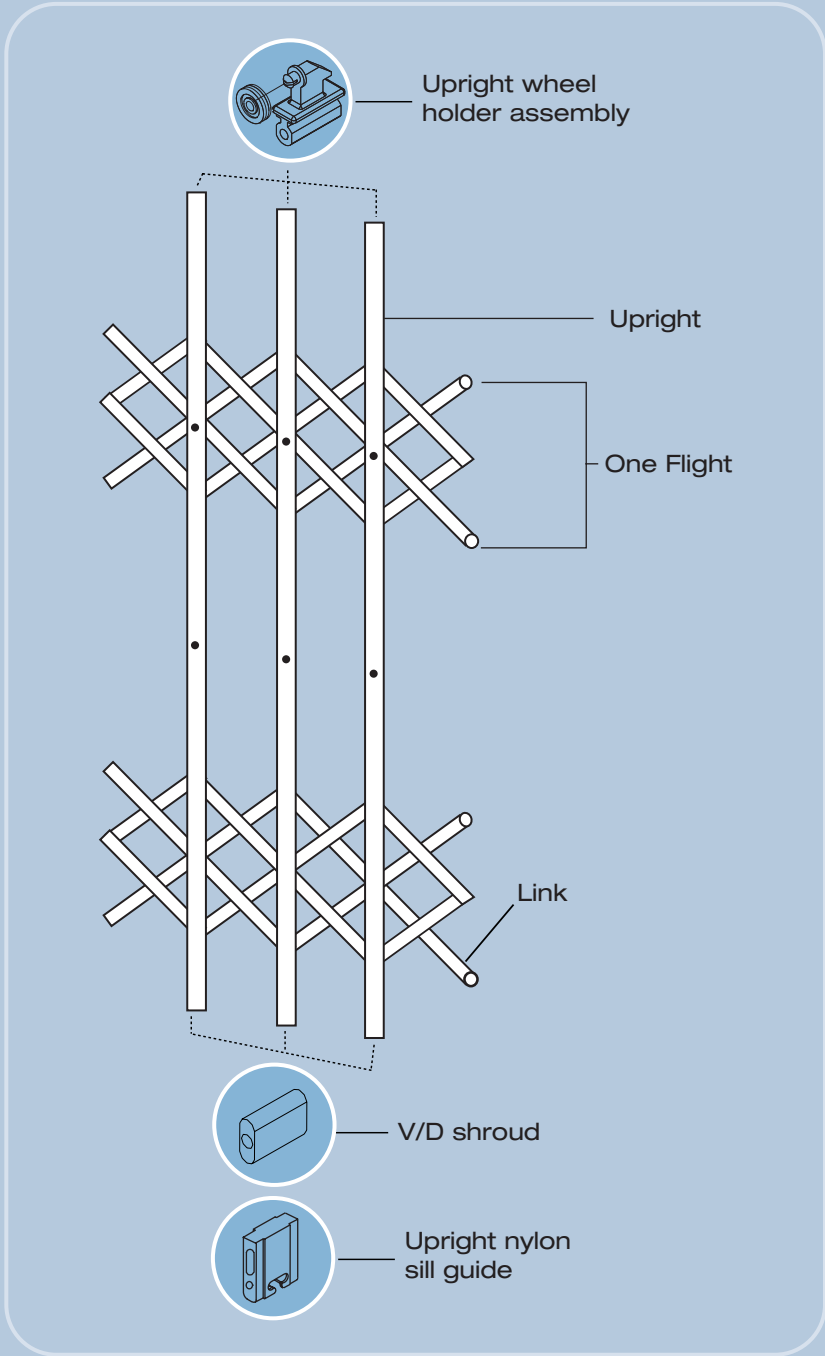

5.3 LOCKS

STANDARD LOCKING MECHANISM

TRELLILOK (Patented)

This unique patented lock was specifically designed for the Trellidor product range and provides dead locking for added security. It consists of a single throw, single key point mechanism with multi-point locking locations.

EURO-LOCK

Where the Trellilok has to match an existing locking system with identical keys, the unique patented Euro-lock is available. This lock will accommodate any euro profile cylinder and this must be specified when ordering.

TRELLIDOR SLAM-LOCK (Patented)

Trellidor product and incorporates the Trellilok Technology. It consists of a double-throw Trellilok, giving multi point locking from a single key point, with 3 modes of operation (from convenience to security).

- > **Open Mode:** In this mode the unit can open and close freely. No locking takes place which prevents accidental lock-out.
- > **Slam-Lock Mode:** A single turn of the key engages the Slam-Lock action. The door is now 'armed' and ready to be Slam-Locked.
- > **Dead-Lock Mode:** After closing the door in the Slam-Lock mode, turn the key one more time and the door is now 'Dead-Locked' which prevents the latches from being lifted.

TRELLILOK

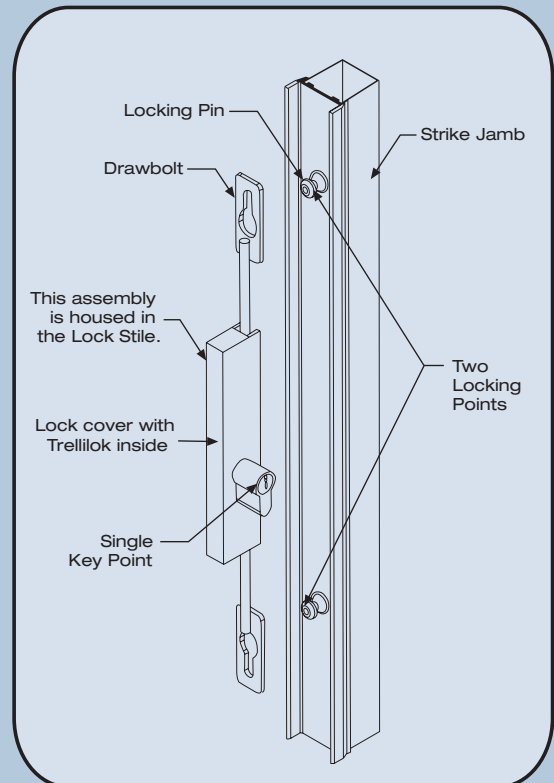

TRELLIDOR SLAM-LOCK

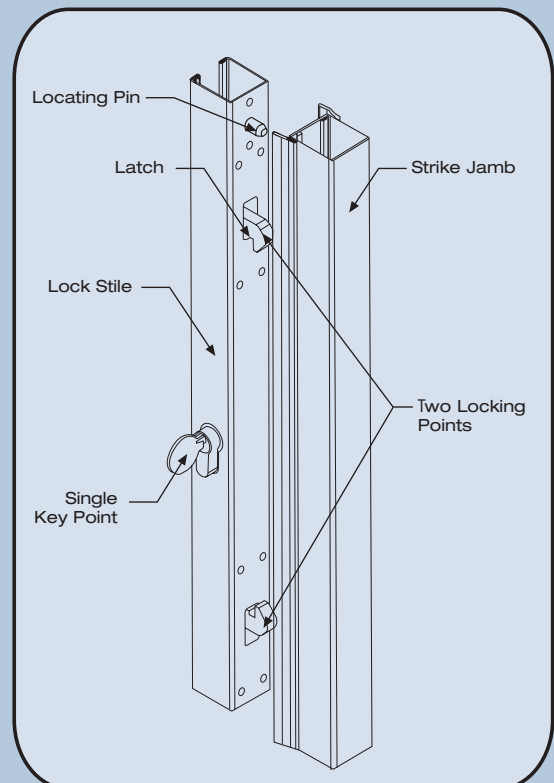

STANDARD LOCKING MECHANISM CONT.

CYLINDERS

The above locks are activated by means of 5 pin cylinders through customised cams.
The cylinders come in a variety of options:

- > **Full cylinders:** Operated from both sides – usually door applications.
- > **Half cylinders:** Operated from one side only – usually window applications.

These can be configured:

- > **Random** (all keys differ)
- > **Matching** (keyed alike)
- > **Dependent**

and/or in combinations of the above.



A

DOORS

ANGLE JOINED

Trellidors can be made to meet at any angle. These are manufactured as double units with the two sashes locking into one another at a specified angle from 90° to 180°.

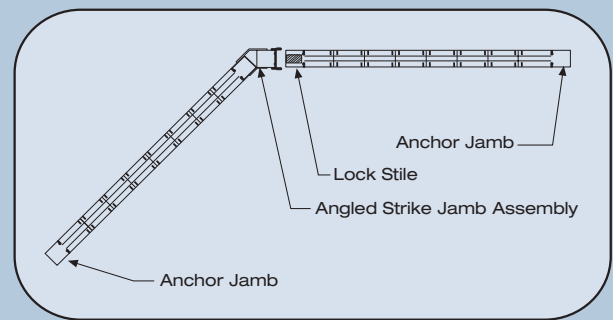

SIDE-BY-SIDE

The side-by-side Trellidor is available in single and double configurations.

- > The unit is designed primarily to maximise the reveal clearspace and minimise stacking size by running two or more cross locking Trellidors parallel.
- > Ideal for shop fronts in malls, shop windows, passageways etc.

Sash sizes are limited to 6000mm per sash.

Cross locking is standard to provide greater security when the Trellidors are in place.

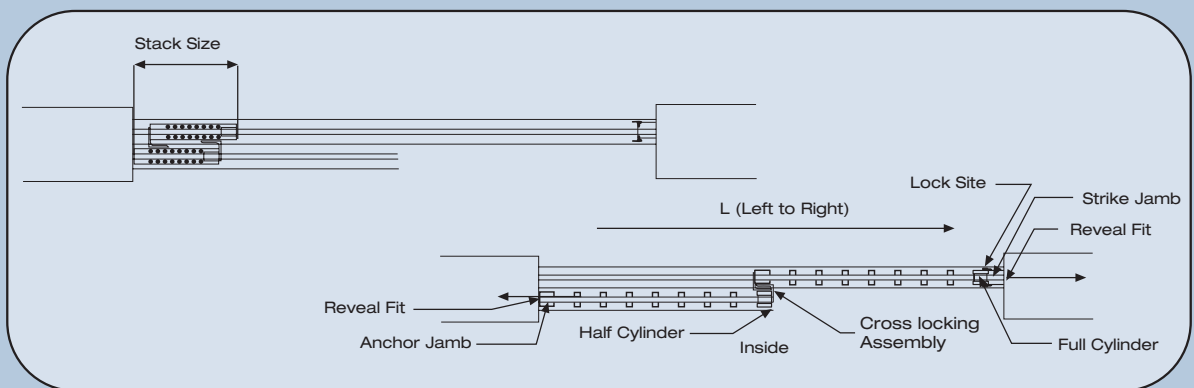

HINGE AWAY

- > The inclusion of a heavy duty hinge mechanism into the single or double Trellidor allows the door stack to be swung away giving wider access through the reveal.
- > Ideal in passageways, smaller doorways and entrances needing full reveal access etc.

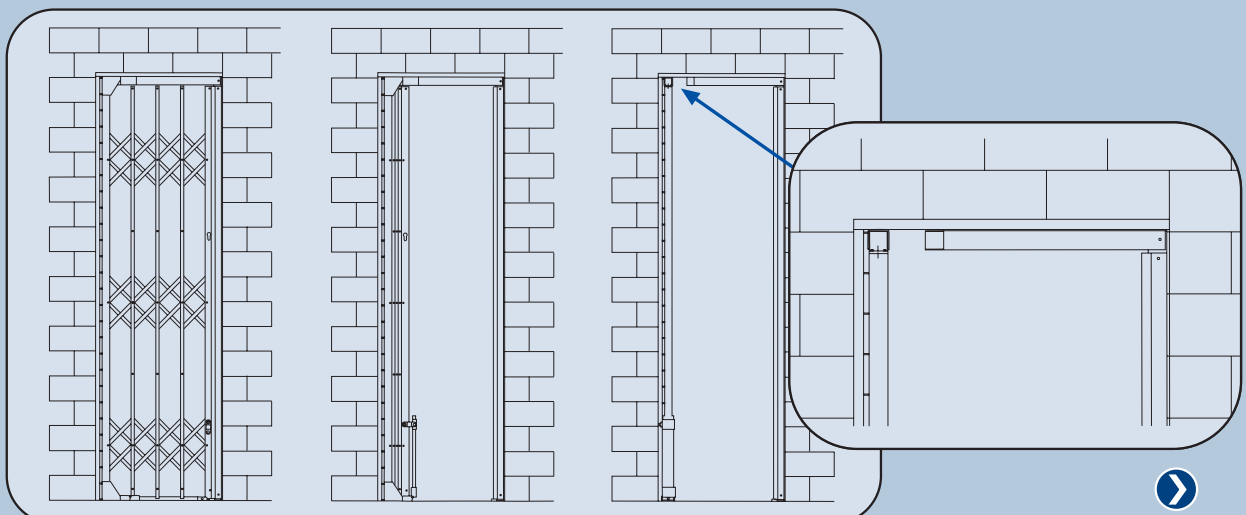

OPTIONS

B WINDOWS

SLIDING

- > Fully framed in galvanised steel and made to fit windows of all sizes.
- > Covers the complete window and retracts away when not needed offering an unobstructed view.
- > Available in single, double, single flexi or double flexi configuration to make window cleaning easy and provide an escape route in the event of an emergency.

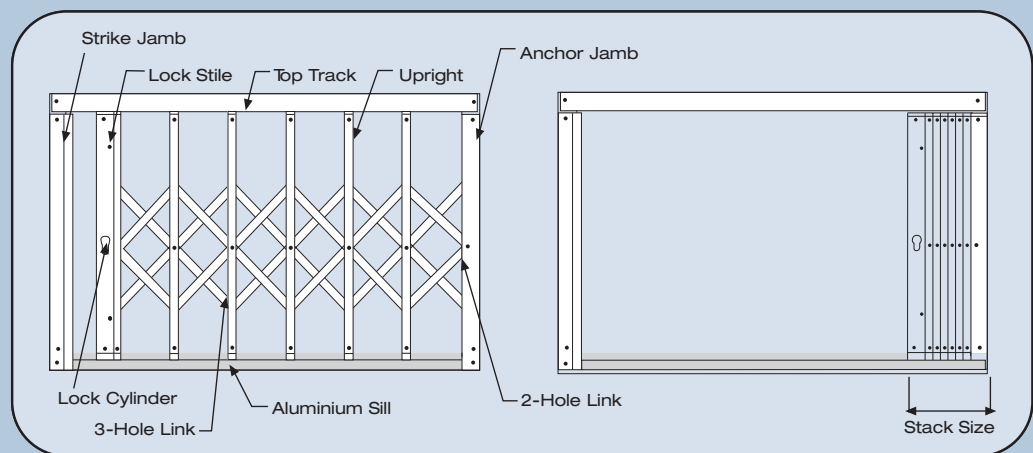

FIXTURE (NON-OPENING)

- > Fully framed in galvanised steel and made to fit all window sizes.
- > Protects opening and fixed window panes.
- > Allows for air circulation with your security in place.

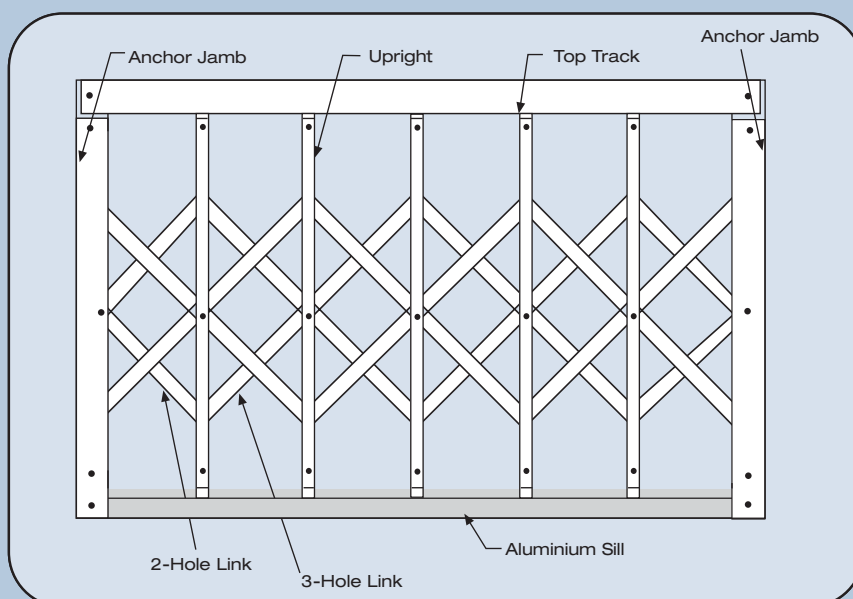

A

STANDARD CONFIGURATIONS

SINGLE SASH TRELLIDOR

One side of the trellis sash is fixed to the anchor jamb, with the other side moving across to lock onto the strike jamb. The direction of close can be left to right or right to left as required.

DOUBLE SASH TRELLIDOR

Double doors have two sashes, stacking one on each side of the unit which closes towards the centre. The split is usually central (50/50), but can be offset to either side as required.

SINGLE FLEXI SASH TRELLIDOR

Constructed with a lock stile and strike jamb on both sides of the unit enabling the stack to be positioned anywhere within the frame. This facilitates cleaning of windows.

DOUBLE FLEXI SASH TRELLIDOR

As per the single sash flexi but with the sash split into two interlocking stacks. This enables each stack to be independently positioned. Each sash locks into the strike jamb at each end of the unit and locks at the centre point as well. Especially designed for large commercial applications.

FIXED SASH TRELLIDOR

The trellis sash construction is fixed to the anchor jamb both left and right as opening is not required in such units.

SINGLE SASH

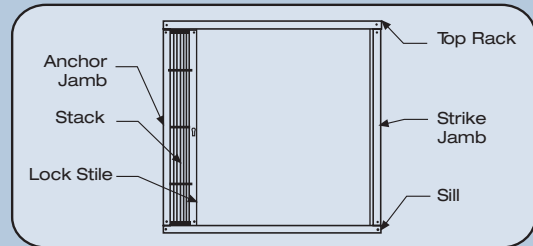

DOUBLE SASH

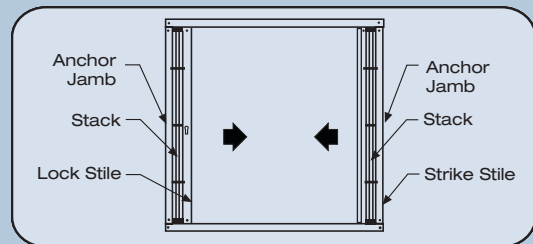

SINGLE FLEXI SASH TRELLIDOR

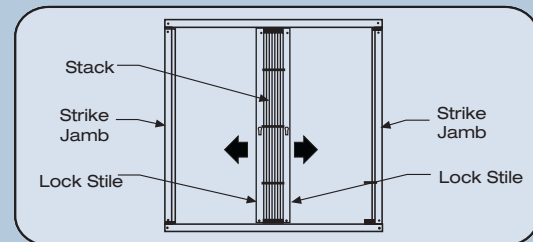

DOUBLE FLEXI SASH TRELLIDOR

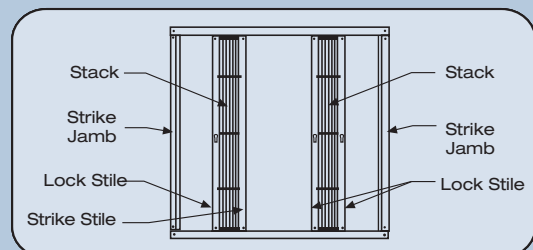

FIXED SASH TRELLIDOR

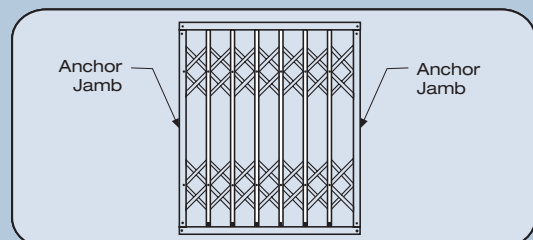

8 FINISHES

Trellidor grilles are available in an attractive stock range of colours (as indicated below), utilising high quality ultra violet resistant polyester powder suitable for interior and exterior use. Additionally they can be supplied in any standard RAL number and can be matched to decor or corporate identity. These colours are representative only. For an exact match please call for a swatch.

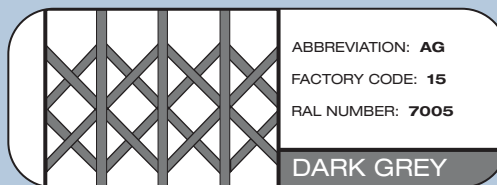
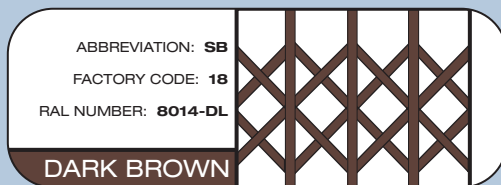
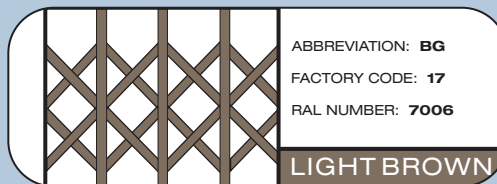
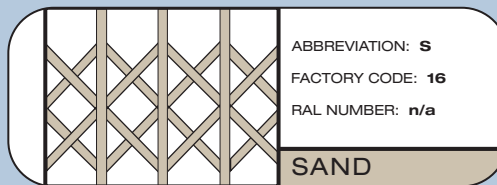
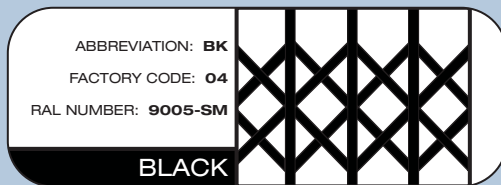
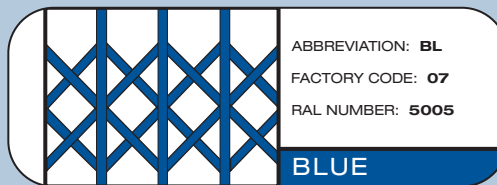
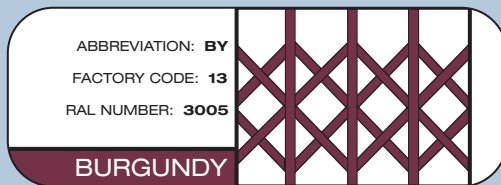
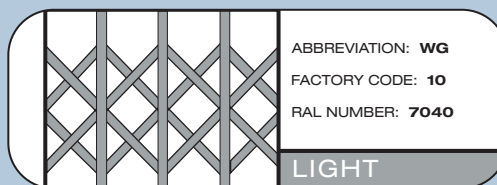
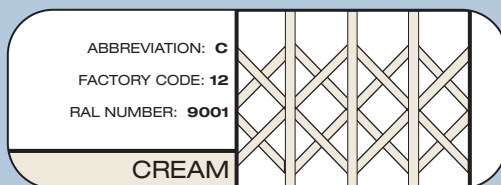
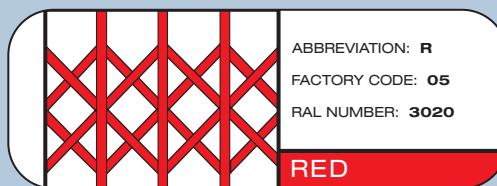
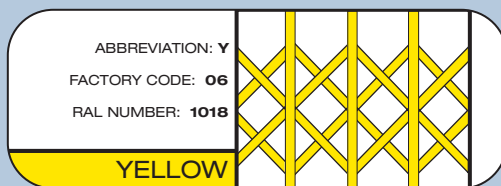
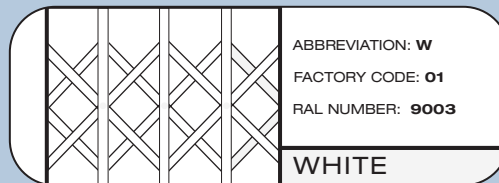

COACH SCREWS

Customised coach screws are used to secure Trellidor by means of a specially designed torx drive attached to a flexi-spanner.

FIXING OPTIONS

Reveal Fixing

- Secured into the walls from all sides.

Face-on Fixing

- This is used when the unit is secured to the face of the aperture. This enables arches to be secured from the inside while maintaining the arched effect from outside.

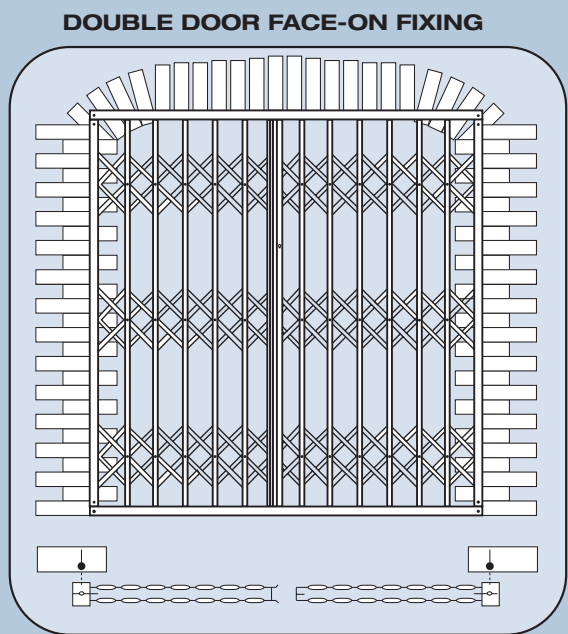
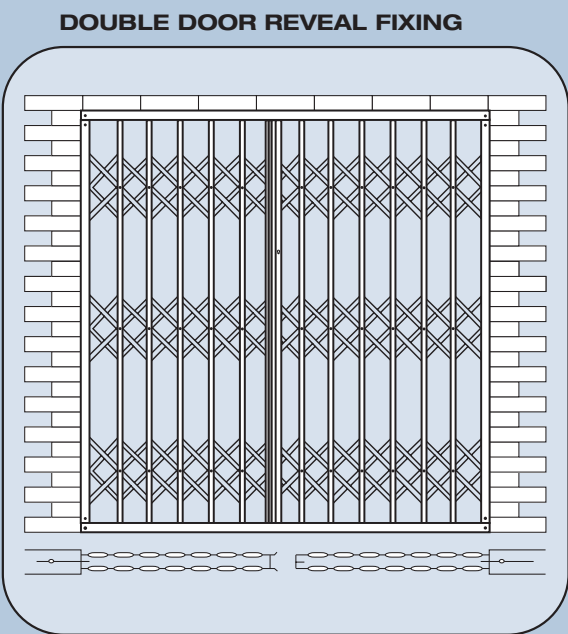

- Other Fixing options include
- face-on to reveal
 - face-on to free standing
 - reveal to free standing
 - free standing

Accessories required to carry out the above fixing options will depend upon on-site conditions and the aperture to be secured. Such accessories could include custom brackets, standard brackets, beams, posts, cover strips. For standard accessories refer below.

INSTALLATION

All units supplied with standard concrete fixing kits.

STANDARD ACCESSORIES

STANDARD BEAM & POST SIZES	STANDARD BRACKET SIZES	STANDARD COVERSTRIP SIZES
32 x 32 x 1.6	30 x 30	100 x 50
50 x 50 x 2	30 x 50	60 x 40
63 x 32 x 1.2	40 x 40	60 x 30
100 x 50 x 2	40 x 60	30 x 30

